

Produto
Certificado



OCP 0018

TOMADAS PARA APARELHOS

ESPECIFICAÇÕES:

CARACTERÍSTICAS ELÉTRICAS: 10A ou 20A em tensões de até 250V~.

MODELOS COM POÇO EXTERNO OU INTERNO.

ATENDEM AO PADRÃO BRASILEIRO DE PLUGUES E TOMADAS (NBR 14136).

REFERÊNCIA	Nº de Condutores	Poço
TPA1 - 2	2	Externo
TPA1 - 3	3	Externo
TPA2 - 2	2	Interno
TPA2 - 3	3	Interno

NÚMERO DE CONDUTORES:

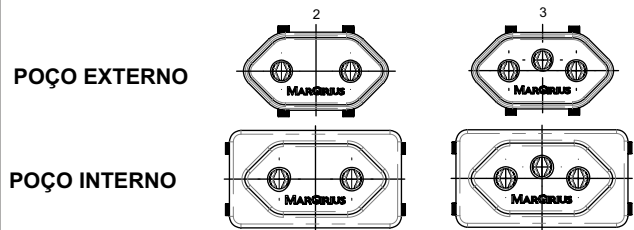

DIMENSÕES

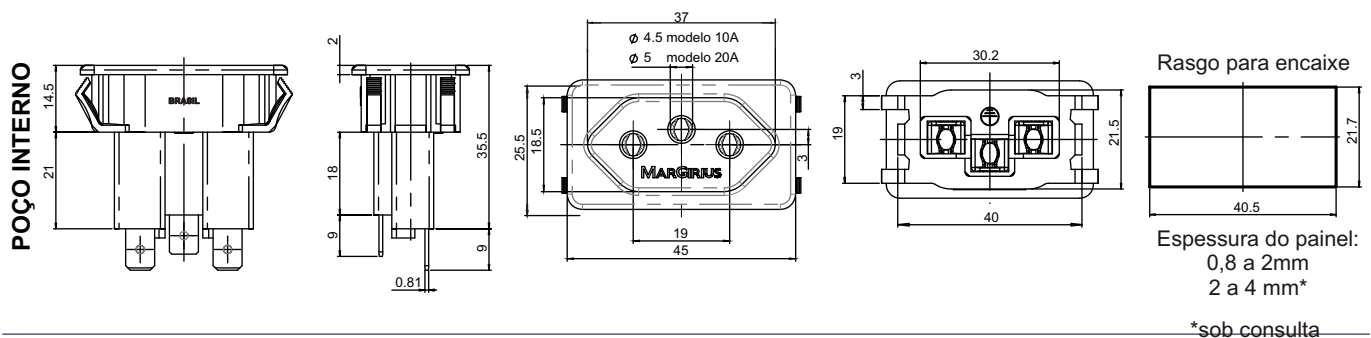
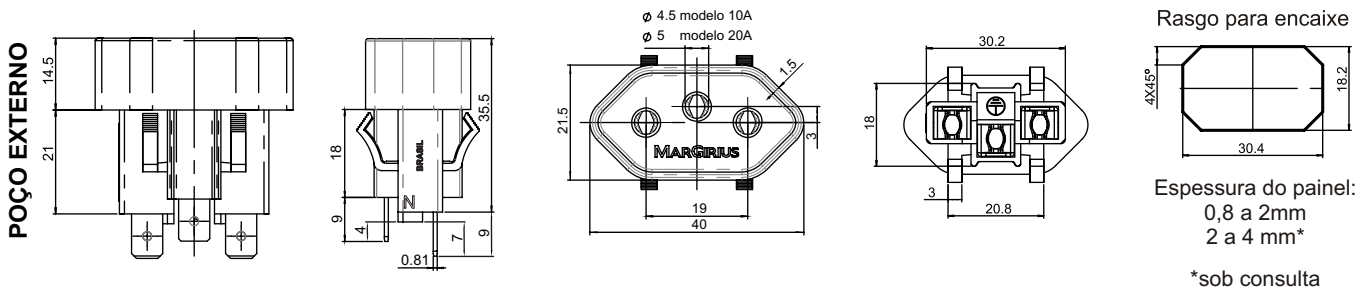

TERMINAIS

E1 - Faston
2,8 x 0,8mm

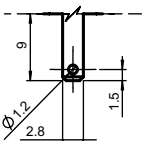

E2 - Faston
4,8 x 0,8mm

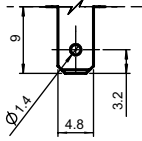

E3 - Faston
6,3 x 0,8mm

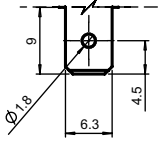

E4 - Faston c/rasgo
6,3 x 0,8mm

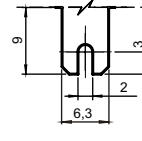

CI - Terminal
PC

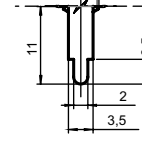

Cabo - Rabicho 150mm*
3 x 1,5mm²

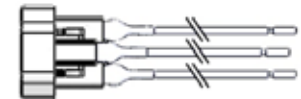

*Outros comprimentos e bitolas sob consulta